



**Document for Tender**  
**(39 /2022)**  
**(46 Pages)**

**Supply of:**

- **Galvanized Tubular Steel Poles for the support of Medium Voltage Overhead electrical networks.**

**Tenderer:**

- **Name:** .....
- **Address:** .....
- **Telephone / Cellular:** .....
- **Fax:** .....
- **Website:** .....
- **E-Mail:** .....
- **Contact Person:** .....

Tender summary mentioned in page (4-7) shall be fill by the tenderer, otherwise his tender will not be considered.

**Tender document cost = 350 JD.**



## List of Contents

Table no.1

<b>No.</b>	<b>Description</b>	<b>Page</b>
<b>1</b>	Cover Page	<b>1</b>
<b>2</b>	List of Contents	<b>2</b>
<b>3</b>	Invitation to Tender	<b>3</b>
<b>4</b>	Tenders summary form	<b>4-7</b>
<b>5</b>	General Conditions	<b>8-17</b>
<b>6</b>	Tendering Instructions	<b>18-21</b>
<b>7</b>	General requirements	<b>22-25</b>
<b>8</b>	Inspection and Testing	<b>26-27</b>
<b>9</b>	Form of Bid Bond	<b>28</b>
<b>10</b>	Form of Performance Bond	<b>29</b>
<b>11</b>	Technical specifications	<b>30-38</b>
<b>12</b>	Special Requirements	<b>39</b>
<b>13</b>	Delivery Period table	<b>40</b>
<b>14</b>	Departures from Specifications - Schedule (1)	<b>41</b>
<b>15</b>	Manufacturing and Testing - Schedule (2)	<b>42</b>
<b>16</b>	Price Summary and Delivery - Schedule (3)	<b>43</b>
<b>17</b>	Price Summary and Delivery - Schedule (4)	<b>44</b>
<b>18</b>	Inspection details – schedule (5+6).	<b>45</b>
<b>18</b>	Tender Agreement Summary	<b>46</b>

**Invitation to Tender**  
**No. (39 /2022)**

Dear Sir;

You are kindly requested to tender for the supply of the below mentioned materials as per the quantities and technical specifications enclosed herewith, by filling in the schedules, signing the form of tender, and forward the complete tender documents to the attention of **IDECO - Director General** addressed as seen on the cover page, to be received not later than 2 pm (local time) due **August 17, 2022.**

All bids must be accompanied with a Bid Bond of a value not less than 5% of the highest alternative tender price, otherwise your tender will not be considered. The bid bond shall be enclosed in the same envelope of the tender and must be delivered to tenders secretary office located in Supplies Department – Tenders Division not later than 2 pm (local time) due **August 17, 2022.**

**Table No.2**

<b>Item No.</b>	<b>Quantity (Pcs)</b>	<b>Material Description</b>	<b>Stock Code</b>
1	1000	Medium Voltage, 17m length, Galvanized Steel poles , consist of 8” & 7” &6” pipes.	9510-1200
2	1100	Medium Voltage, 15m length, Galvanized Steel poles , consist of 8” & 7” &6” pipes.	9510-1201
3	50	Medium Voltage, 14m length, galvanized Steel poles consist of 8” & 7” &6” pipes.	9510-1202
4	130	Medium Voltage, 12m length, galvanized Steel poles, consist of 8” & 7” &6” pipes.	9510-1204
5	510	Medium Voltage, 10m length, galvanized Steel poles, consist of 8” & 7” pipes.	9510-1205

**Tender Summary for Tender No. 39/2022**

**These 3 pages must be completely filled out by the bidder; otherwise it may be a reason for exclusion from the bidding competition:**

<b>Name of bidder:</b>		
<b>Address:</b>		
<b>Telephone/Cellular/Fax</b>		
<b>E- Mail</b>		
<b>Contact Person:</b>		
<b>Name of the manufacturer and country of origin:</b>		
<b>The value of the bid bond and the bank issued from:</b>		
<b>The total value of the bid:</b>	<b>Currency</b>	
	<b>Total price</b>	<b>Including Sales tax &amp; custom fees</b>
		<b>Exclude sales tax &amp; custom fees</b>
		<b>exempt</b>
	<b>Total price in writing</b>	
<b>Delivery</b>	<b>Ex-works delivery</b>	
	<b>Aqaba port delivery</b>	
	<b>Ideco stores delivery</b>	
<b>Testing</b>	<b>Place of manufacturing</b>	
	<b>Place of testing</b>	
<b>Cost for inspection &amp; testing:</b>		

**Official signature and seal / Bidder**

**Irbid Electricity Company Use:**

**Chairman of the Committee**

**Deputy Chairman of the Committee**

**Committee member**

**Committee member**

**Committee member**

**Committee member**

**Committee member**

**Departures**

<b>Departures from</b>	<b>Technical specifications</b>	<b>Required</b>	<b>offered</b>
	<b>Special requirements</b>	<b>Required</b>	<b>offered</b>

**Official signature and seal / Bidder**

**Irbid Electricity Company Use:**

**Chairman of the Committee**

**Deputy Chairman of the Committee**

**Committee member**

**Committee member**

**Committee member**

**Committee member**

**Committee member**

- 1- **General Condition**: We committed to implementing all items mentioned in the general conditions within the bid document number (        ), and the subcategories of these items.
- 2- **Tendering Instructions**: We committed to implementing all items mentioned in the tendering instructions within the bid document number (        ), and the subcategories of these items.
- 3- **General Requirement (Standards and Regulation)** : We committed to implementing all items mentioned in the general conditions within the bid document number (        ), and the subcategories of these items.
- 4- **Inspection and testing**: We committed to implementing all items mentioned in the inspection and testing within the bid document number (        ), and the subcategories of these items.
- 5- **Special Requirements**: We committed to implementing all items mentioned in the special requirements within the bid document number (        ), and the subcategories of these items.
- 6- We committed to fill out all the required pages with the bid documents, without any discrepancies with similar information contained in the Tender Summary.
- 7- We committed that in case there is a difference in the prices provided by us, the lower price will be approval.
- 8- Based on the above we sign.

**Official signature and seal / Bidder**

<b><u>Irbid Electricity Company Use:</u></b>
--

**Chairman of the Committee**

**Deputy Chairman of the Committee**

**Committee member**

**Committee member**

**Committee member**

**Committee member**

**Committee member**

**In case there are any comments or additional terms or other offers by the bidder; it must be mentioned or Brief about it in the summary of this page:**

**Official signature and seal / Bidder**

**Irbid Electricity Company Use:**

**Chairman of the Committee**

**Deputy Chairman of the Committee**

**Committee member**

**Committee member**

**Committee member**

**Committee member**

**Committee member**

# GENERAL CONDITIONS

- The below are general conditions of contract for the supply and delivery of plant and materials based on United Nations economic commission for Europe publication ref.: me/ 188 Geneva. March, 1953.

## 1. Preamble

**1.1.** These General Conditions shall apply, save as varied by express agreement accepted in writing by both parties.

### 1.2. Definition of Terms:

The "Purchaser" shall mean "Irbid District Electricity Co. Ltd." Hereinafter called "IDECO", and shall include IDECO's legal personal representatives and duly appointed engineers. The "Engineer" shall mean "Irbid District Electricity Co." or persons for the time being or from time to time duly appointed in writing by the purchaser to act as Engineer or the purpose of the contract.

The words "approved" and "approval" where used in these conditions or in the specification shall mean "approved by" and "approval of" the purchaser respectively. The "Vendor" shall mean the "Contractor" whose tender has been accepted by the purchaser and shall include the Vendor's. (Contractor's) legal personal representatives, successors and permitted assigns, "F.O.B. Price" shall mean the cost of the equipment delivered free on board the ship or truck or aircraft, all port charges and handling charges (also heavy lift if applicable) included .

The contractor must insure the material against all risks from the time it leaves the works until it is placed F.O.B "C&F price" shall mean F.O.B. price plus freight including unloading at the port of destination. All Marine Insurance will be effected by the purchaser. The contractor must provide full details of the material to be shipped in good time for IDECO to arrange for Marine Insurance before the material is actually shipped.

## 2. Formation of Contract

**2.1.** The contract shall be deemed to have been entered into when the purchaser has sent an acceptance in writing before the time set in the tender for acceptance or any such later date extended by the tenderer at the request of the purchaser.

**2.2.** Notwithstanding that the contract and correspondence in connection with the contract shall be in the English language, the contract shall be and be deemed to be a Jordan contract and shall accordingly be governed by and construed according to the laws for the time being in force in the Hashemite Kingdom of Jordan.

**2.3. Power to Vary The Work:** alternations, amendments, omissions, additions, suspensions, or variations of the work, (hereinafter referred to as "variations") under the contract as shown by the contract drawings or the specification shall be made by the contractor except as directed in writing by the purchaser, but the purchaser shall have full power, subject to the provision hereinafter contained, from time to time during the execution of the contract by notice in writing to instruct the contractor to make such variation without prejudice to the contract and the contractor shall carry out such variations, and be bound by the same conditions, as far as applicable, as though the said variations occurred in the specification. If any suggested variations would, in the opinion of the contractor, if carried out, prevent him fulfilling any of his obligations or guarantees under the contract, he shall notify the



purchaser thereof in writing, and the purchaser shall decide forthwith whether or not the same shall be carried out, and if the purchaser confirms his instructions, the contractor's obligations and guarantee shall be modified to such an extent as may be justified. The difference in cost, if any, occasioned by any such variations, shall be added to or deducted from the contract price as the case may require. The amount of such difference, if any, shall be ascertained and determined in accordance with the rates specified in the schedule of prices so far as the same may be applicable, and **where the rates are not contained in the said Schedule, or are not applicable they shall be settled by the purchaser and the contractor jointly. But the purchaser shall not become liable for the payment of any charge in respect of any such variations, unless the instruction for the performance of the same shall have been given in writing by him. In the event of the purchaser requiring any variation, such reasonable a proper notice shall be given to the contractor as will enable him to make his arrangements accordingly, and in cases where goods or materials are already prepared, or any designs, drawings, or patterns made or work done that requires to be altered a reasonable sum in respect thereof shall be allowed by the purchaser. Provided that no such variations shall, except with consent in writing of the contractor, be such as will involve an increase or decrease of the total price payable under the contract by more than 25 percent thereof. The power given to the purchaser to make any alteration, amendment, omission, addition or variation to, from or in any part of the works shall include power to vary from time to time the date for the completion of the works or any part thereof, also the purchaser shall have the absolute right to increase the quantities in such manner that the increment does not exceed the amount of 25% of the total price payable under the contract, however; the same prices awarded and any other relevant conditions shall remain the same for this purpose. This right is valid during the tender validity and within 120 days from the date of the order letter, and during delivery period.**

**2.4. Precedence:** In the event of any discrepancy or contradiction between the provisions of the conditions of contract and of the specification, the conditions of contract shall take precedence.

**2.5. Prices:** The Tender calls for firm prices.

### **3. Drawings and Descriptive Documents**

**3.1.** The weights, dimensions, capacities, prices, performance rating and other data included in catalogues, prospectuses, circulars, advertisement, illustrated matter and price lists constitute an approximate guide. These data shall not be binding save to the extent that they are by reference expressly included in the contract.

**3.2.** Any drawings or technical documents intended for use in the construction of the material or of part thereof and submitted to the purchaser prior or subsequent to the formation of the contract remain the exclusive property of the Vendor. They may not, without the Vendor's consent, be utilized by the purchaser or copied, reproduced, transmitted or communicated to a third party. Provided, however, that the said plans and documents shall be the property of the purchaser.

**a.** If it is expressly so agreed, or

**b.** If they are referable to a separate preliminary development contract on which no actual construction was to be performed and in which the property of the Vendor in the said plans and documents was not reserved.

**3.3.** Any drawings or technical documents intended for use in the construction of the material or

of part thereof and submitted to the Vendor by the Purchaser prior or subsequent to the formation of the contract remain the exclusive property of the Purchaser. They may not, without his consent be utilized by the Vendor or copied, reproduced, transmitted or communicated to a third party.

**3.4.** The Vendor shall, if required by the purchaser, furnish free of charge to the purchaser at the commencement of the Guarantee Period, as defined in clause 9, information and drawings other than manufacturing drawings of the material in sufficient detail to enable the purchaser to carry out the erection, commissioning, operation and maintenance (including running repairs) of all parts of the material. Such information and drawings shall be the property of the purchaser and the restrictions on their use set out in paragraph 2 hereof shall not apply thereto. Provided that if the Vendor so stipulates, they shall remain confidential.

#### **4. Materials Packing and Shipping Marks**

All materials, equipment and goods shall be very well packed, in seaworthy containers and/or wooden cases, etc. These should protect the material during shipping, handling, unloading, and for a reasonable period of storage at Aqaba and latter storage at IDECO stores. Packing for indoor materials should be done in such manner as to adequately ensure no ingress of moisture during the shipping and storage periods. Packing of fragile equipment (e.g. including instruments and porcelain) should be done in a way which ensures a reasonable resistance to impact breakage during transport. Packing shall in general be adequate and in compliance with the best international practice. A descriptive and fully itemized list shall be prepared for the contents of each packing case. A copy of this list shall be placed in a waterproof envelope under a metal or other suitable plate securely fastened to the outside of one end of the case. And its position adequately indicated by stenciling on the case. Where appropriate drawing showing the erection marking of the items concerned shall be placed inside the case, IDECO will supply the successful tenderer with a drawing of its shipping mark for utilization. All packing cases, crates, barrels and drums shall remain the property of the purchaser.

#### **5. Inspection and Testing**

**5.1.** If expressly agreed in the contract, the purchaser shall be entitled to have the quality of the materials used and the parts of the instruments, both during manufacture and when completed, inspected and checked by his authorized representatives. Such inspection and checking shall be carried out at the place of manufacture during normal working hours after agreement with the Vendor as to date and time.

**5.2.** If as a result of such inspection and checking the purchaser shall be of the opinion that any materials or parts are defective or not in accordance with the contract, he shall state in writing his objections and the reasons therefore.

**5.3. TESTS:** Acceptance tests will be carried out and, unless otherwise agreed, will be made at the Vendor's works and during normal working hours. If the technical requirements of the tests are not specified in the contract, the tests will be carried out in accordance with the general practice obtaining in the appropriate branch of the industry in the country where the material is manufactured.

**5.4.** The Vendor shall give to the purchaser sufficient notice of the tests to permit the purchaser's representatives to attend. If the purchaser is not represented at the tests, the tests report shall be communicated by the Vendor to the purchaser and shall be accepted as accurate by the purchaser.

**5.5.** If on any test (other than a test site, where test on site are provided for in the contract) the

material shall be found to be defective or not in accordance with the contract, the Vendor shall with all speed make good the defect or ensure that the plant complies with the contract. Thereafter, if the purchaser so requires, the test shall be repeated.

5.6. Unless otherwise agreed, the Vendor shall bear all the expenses of tests carried out in his works.

5.7. If the contract provides for tests on site, the terms and conditions governing such tests shall be such as may be specially agreed between the parties.

## 6. Passing of Risk

Save as provided in paragraph 7.6, the time at which the risk shall pass shall be fixed in accordance with the International Rules for the Interpretation of Trade Terms (Incoterms) of the International Chamber of Commerce in force at the date of the formation of the contract.

## 7. Delivery:

7.1. Unless otherwise agreed the delivery period shall run from the latest of the following dates:

- a. The date of the formation of the contract as defined in clause 2.
- b. The date on which the Vendor receives notice of the issue of a valid import license where such is necessary for the execution of the contract.
- c. The date of the receipt by the Vendor of such payment in advance of manufacture as stipulated in the contract.

7.2. Should delay in delivery be caused by any of the circumstances mentioned in clause 10 or by an act or omission of the purchaser and whether such cause occur before or after the time or extended time for delivery, there shall be granted subject to the provisions of paragraph 5 hereof such extension of the delivery period as is reasonable having regard to all the circumstances of the case.

7.1. If a fixed time for delivery is provided for in the contract and the Vendor fails to deliver within such time or any extension thereof granted under paragraph 2 hereof, the purchaser shall be entitled, on giving to the Vendor within a reasonable time notice in writing, to claim a deduction of the price payable under the contract. Such deduction shall be calculated at the rate of one half of one percent of that part of the price payable under the contract which is properly attributable to such portion of the plant as cannot in consequence of the said failure be put to the use intended for each complete week of delay commencing on the due date of delivery, but shall not exceed a maximum percentage deduction of ten percent. Such deduction shall be allowed when a payment becomes due on or after delivery. Save as provided in paragraph 5 hereof, such deduction of price shall be to the exclusion of any other remedy of the purchaser in respect of the Vendor's failure to deliver as aforesaid. **(In case the required material shall be delivered in number of shipments, then the maximum percentage deduction of ten percent shall be applied on amount of each shipment).**

7.2. If the time for delivery mentioned in the contract is an estimate only, either party may after the expiration of two thirds of such estimated time require the other party in writing to agree a fixed time. Where no time for delivery is mentioned in the contract, this course shall be open to either party after the expiration of six months from the formation of the contract. If in either case the parties fail to agree, either party may have recourse to arbitration, in accordance with the provisions of clause 13, to determine a reasonable time for delivery and the time so determined shall be deemed to be the fixed time for delivery provided for in the contract and paragraph 3 hereof shall apply accordingly.

**7.3.** If any portion of material in respect of which the purchaser has become entitled to the maximum deduction provided for by paragraph 3 hereof, or in respect of which he would have been so entitled had he given the notice referred to therein, remains undelivered, the purchaser may by notice in writing to the Vendor require him to deliver and by such last mentioned notice fix a final time for delivery which shall be reasonable taking into account such delay as has already occurred. If for any reason whatever the Vendor fails within such time to do everything that he must do to effect delivery, the purchaser shall be entitled by notice in writing to the Vendor, and without requiring the consent of any court, to terminate the contract in respect of such portion of the material and thereupon to recover from the Vendor any amount not exceeding that part of the price payable under the Contract which is properly attributable to such portion of the material as could not in consequence of the Vendor's failure be put to the use intended.

**7.4.** If the purchaser fails to accept delivery on due date, he shall nevertheless make any payment conditional on delivery as if the material had been delivered. The Vendor shall arrange for the storage of the material at the risk and cost of the purchaser. If required by the purchaser, the Vendor shall insure the material at the cost of the purchaser. Provided that if the delay in accepting delivery is due to one of the circumstances mentioned in clause 10 and the Vendor is in a position to store it in his premises without prejudice to his business, the cost of storing the material shall not be borne by the purchaser.

**7.5.** Unless the failure of the purchaser is due to any of the circumstances mentioned in clause 10, the Vendor may require the purchaser by notice in writing to accept delivery within reasonable time. If the purchaser fails for any reason whatever to do so within such time, the Vendor shall be entitled by notice in writing to the purchaser, and without requiring the consent of any court, to terminate the contract in respect of such portion of the material as is by reason of the failure of the purchaser aforesaid not delivered and thereupon to recover from the purchaser any loss, suffered by reason of such failure up to an amount not exceeding the value of the material, the delivery of which has not been accepted.

## **8. Force Majeure**

**8.1.** Notwithstanding the provisions of clauses 7, the supplier shall not be liable for forfeiture of its performance security, liquidated damages or termination for default, if and to the extent that, its delay in performance or other failure to perform its obligations under the contract is the result of an event of Force Majeure.

**8.2.** For purposes of this clause, "Force Majeure" means an event beyond the control of the supplier not involving the supplier's fault or negligence. Such events may include, but are not restricted to, acts of God, acts of the purchaser either in its sovereign or contractual capacity, wars or revolutions, fires, floods, epidemics, quarantine restrictions and freight embargoes.

**8.3.** If a Force Majeure situation arises, the supplier shall promptly notify the purchaser in writing of such condition and the cause thereof. Unless otherwise directed by the purchaser in writing, the supplier shall continue to perform its obligations under the contract as far as is reasonably practical, and shall employ all reasonable alternative means for performance not prevented by the Force Majeure event.

## **8.4. Payment:**

### **8.4.1 Terms of Payment:**

- 1. The company prefers to deal with the supplier on an open account basis, and the payment to be made as the following:**

- a. The supplier's shall be submitted the following documents by IDECO: (Invoice origin + five copies), (Certificate of origin + five copies), (Bill of lading 3-negotiable + 5 non-negotiable), (Test certificate (where applicable) + 6 copies), and those documents shall be legalized for shipping, and those documents shall be legalized for shipping purposes.
  - b. 100% of the invoice value to be paid within one month of (Receipt of IDECO acceptance certificate, Receipt of goods at IDECO stores).
  - c. Payment will be released on first week of each month.
2. In case the supplier insists on L/C as a method of payment, all/LC charges will be born by the supplier and charge to his own account and the terms will be as follows:
- a. The L/C will be confirmed and irrevocable but has to be acceptance L/C and the supplier has to send the following documents: (Invoice origin + five copies), (Certificate of origin + five copies), (Bill of lading 3-negotiable + 5 non-negotiable), (Test certificate (where applicable) + 6 copies), and those documents shall be legalized for shipping purposes.
  - b. Payment will be released after submitting IDECO's acceptance certificate to the bank within one month after receipt of goods at IDECO's stores.
  - c. Payment will be released on first week of each month.
- 8.4.2 Currency of Payment:** The contract price will normally be paid in the currency or currencies in which the price has been stated. The purchaser, however, reserves the right to make payments in the currencies of the countries of origin of goods and services at the exchange rates applicable at the time of payment of the contract price.
- 8.4.3** Any advance payments made by the purchaser are payments on account and do not constitute a deposit, the abandonment of which would entitle either party to terminate the contract.
- 8.4.4** If delivery has been made before payment of the whole sum payable under the contract, material delivered shall, to the extent permitted by the law of the country where the plant is situated after delivery, remain the property of the Vendor until such payment has been effected. If such law does not permit the Vendor to retain the property in the material, the Vendor shall be entitled to the benefit of such other rights in respect thereof as such law permits him to retain. The purchaser shall give the Vendor any assistance in taking any measures required to protect the Vendor's right of proper or such other rights as aforesaid.
- 8.4.5** A payment conditional on the fulfillment of an obligation by the Vendor shall not be due until such obligation has been fulfilled, unless the failure of the purchaser is due to an act or omission of the purchaser.
- 8.4.6** If the purchaser delays in making any payment, the Vendor may postpone the fulfillment of his own obligations until such payment is made, unless the failure of the purchaser is due to an act or omission of the Vendor.
- 8.4.7** If delay by the purchaser in making any payment is due to one of the circumstances mentioned in clause 10, the Vendor shall not be entitled to any interest on the sum due.

**8.4.8** Save as aforesaid, if the purchaser delays in making any payment, the Vendor shall on giving to purchaser within a reasonable time notice in writing be entitled, and without requiring the consent of any court, to terminate the contract and thereupon to recover from the purchaser the amount of his loss up to the value of the material, the payment for which has been unreasonably delayed.

**9. Guarantee:**

- 9.1.** Subject as hereinafter set out; the Vendor undertakes to remedy any defect resulting from faulty design, materials or workmanship.
- 9.2.** This liability is limited to defects which appear during the period (hereinafter called the Guarantee Period) of fifteen months from date of dispatch ex-works or twelve months from the date of setting to work whichever shall be the later.
- 9.3.** In fixing this period due account has been taken of the time normally required for transport as contemplated in the contract.
- 9.4.** In respect of such parts (whether of the Vendor's own manufacture or not) of the material as are expressly mentioned in the contract, the Guarantee Period shall be such other period (if any) as is specified in respect of each of such parts.
- 9.5.** The Guarantee period shall start from the later of the dates mentioned in paragraph 2 above. If however dispatch ex-works is delayed for a period in excess of three months due to a cause beyond the control of the Vendor the Guarantee Period shall not extend beyond eighteen month from the date the material was ready for dispatch ex-works.
- 9.6.** The Guarantee period is based on the continuous use of the material in service for 24 hours every day.
- 9.7.** A fresh Guarantee Period equal to that stated in paragraph 2 hereof shall apply, under the same terms and conditions as those applicable to the original material, to parts supplied in replacement of defective parts or to parts renewed in pursuance of this clause. This provision shall not apply to the remaining parts of material, the Guarantee Period of which shall be extended only by a period equal to the period during which the material is out of action as result of a defect covered by this clause.
- 9.8.** In order to be able to avail himself of his rights under this clause the purchaser shall notify the Vendor in writing without delay of any defects that have appeared and shall give him every opportunity of inspecting and remedying them.
- 9.9.** On receipt of such notification the Vendor shall remedy the defect forthwith and at his own expense. Save where the nature of the defect is such that it is appropriate to effect repairs on site, the purchaser shall return to the Vendor any part in which a defect covered by this clause has appeared, for repair or replacement by the Vendor, and in such case the delivery to the purchaser of such part properly repaired or a part in replacement thereof shall be deemed to be a fulfillment by the Vendor of his obligations under this paragraph in respect of such defective part.
- 9.10.** The Vendor shall bear all the costs and risks of the transport of defective parts or equipments and their replacements.
- 9.11.** Where, in pursuance of paragraph 9 hereof, repairs are required to be effected on site, the conditions covering the attendance of the Vendor's representatives on site shall be such as may be specially agreed between the parties.

- 9.12.** Defective parts replaced according to this clause shall be placed at the disposal of the Vendor.
- 9.13.** If the Vendor refuses to fulfill his obligations under this clause or fails to proceed with due diligence after being required so to do, the purchaser may proceed to do the necessary work at the Vendor's risk and expense, provided that he does so in a reasonable manner.
- 9.14.** The Vendor's liability does not apply to defects arising out of materials provided, or out of a design stipulated, by the purchaser.
- 9.15.** The Vendor's liability shall apply only to defect that appears under the conditions of operation provided for by the contract and under proper use. It does not cover defects due to causes arising after the risk in the material has passed in accordance with clause 6. In particular it does not cover defects arising from the purchaser's faulty maintenance or erection, or from alterations carried out without the Vendor's consent in writing, or from repairs carried out improperly by the purchaser, nor does it cover normal deterioration.
- 9.16.** Save as in this clause expresses, the Vendor shall be under no liability in respect of defects after the risk in the material has passed in accordance with clause 6, even if such defects are due to causes existing before the risk so passed. It is expressly agreed that the purchaser shall have no claim in respect of personal injury or of damage to property not the subject matter of the contract or of loss of profit unless it is shown from the circumstances of the case that the Vendor has been guilty of gross misconduct.
- 9.17.** The vendor is required to transport all the defective or not in accordance materials, from our stores within a month from date of notification. All costs and expenses of transportation shall be borne by the vendor. Unless otherwise agreed. IDECO has the right to deal with the defective materials in a proper way.
- 9.18.** Gross misconduct "does not comprise any and every lack of proper care or skill, but means an act or omission on the part of the Vendor implying either a failure to pay due regard to serious consequences which a conscientious contractor would normally foresee as likely to ensue, or a deliberate disregard of any consequences of such act or omission.
- 10. Relief:**
- 10.1.** The following shall be considered as cases of relief if they intervene after the formation of the contract and impede its performance: industrial disputes, and any other circumstances (e.g. fire, mobilization, requisition, embargo, currency restrictions, insurrection, shortage of transport, general shortage of materials and restrictions in the use of power) when such other circumstances are beyond the control of the parties.
- 10.2.** The party wishing to claim relief by reason of any of the said circumstances shall notify the other party in writing without delay on the intervention and on the cessation thereof.
- 10.3.** The effects of the said circumstances so far as they affect the timely performance of their obligation by the parties, are defined in clauses 7 and 8. Save as provided in paragraph 7.5, 7.7, and 8.7, if by reason of any of the said circumstances, the performance of the contract within a reasonable time becomes impossible, either party shall be entitled to terminate the contract by notice in writing to the other part without requiring the consent of any court.

**10.4.** If the contract is terminated in accordance with paragraph 3 hereof, the division of the expenses incurred in respect of the contract shall be determined by agreement between the parties.

**10.5.** In default of agreement it shall be determined by the arbitrator which party has been prevented from performing his obligations and that party shall bear the whole of the said expenses. Where the purchaser is required to bear the whole of the expenses and has before termination of the contract paid to the Vendor more than the amount of the Vendor's expenses, the purchaser shall be entitled to recover the excess. If the arbitrator determines that both parties have been prevented from performing their obligation, he shall apportion the said expenses between the parties in such manner as to him seems fair and reasonable, having regard to all the circumstances of the case.

**10.6.** For the purposes of this clause "expenses" means actual out of pocket expenses reasonably incurred, after both parties shall have mitigated their losses as far as possible. Provided that as respects material delivered to the purchaser the Vendor's expenses shall be deemed to be that part of the price payable under the contract which is properly attributable thereto.

**11. Limitation of Damages:**

**11.1.** Where either party is liable in damages to the other these shall not exceed the damage which the party in default could reasonably have foreseen at the time of the formation of the contract.

**11.2.** The party who sets up a breach of the contract shall be under a duty to take all necessary measures to mitigate the loss which has occurred provided that he can do so without unreasonable inconvenience or cost. Should he fail to do so, the party guilty of the breach may claim a reduction in the damages.

**12. Rights at Termination:** Termination of the contract from whatever cause arising shall be without prejudice to the rights of the parties accrued under the contract up to the time of termination.

**13. Arbitration and Law Applicable:**

**13.1.** Any dispute, question or controversy shall arise between the purchaser and the contractor concerning this contract the matter in dispute shall be referred to an arbitration committee composed of three (3) arbitrators. One arbitrator shall be nominated by the purchaser and one by the contractor, and the third arbitrator shall be appointed by both parties. If either party fails to appoint his arbitrator within one month of the appointment of the arbitrator by the other party, or if the two parties fail to agree on the third arbitrator within two months of the date of the request to refer the dispute to arbitration, such arbitrator shall be appointed by the president of the highest court in Jordan at the request of either or both parties.

**13.2.** The decision of the arbitrators shall be final and binding on both the purchaser and the contractor. Any such reference shall conform to the statutory enactment or regulation governing arbitration as may be in force in Jordan at the time. The assessment of costs incidental to the reference and award respectively shall be at the discretion of the arbitration committee.



14. The purchaser has the complete right to reply on contractor's clarifications during 7 days, and during this period there is not exemption from incurred penalty for the event.
15. After Awarding Tenders, winner tenderer will be assessment according to quality of good, delivery period, service after sale, and assessment weight will be considered in coming tenders' evaluation.
16. Where the contractor, who was awarded the bid, ceased or failed in implementing the conditions of the bid; IDECO Company has the right to take the appropriate decision on the confiscation of the amount of guarantee or insurance provided by the bidder upon his participation in the tender, In addition, the IDECO company has the right to the restriction of participation of this bidder in all of the company's bids for the duration seen appropriate.
17. The Irbid Electricity Company shall be entitled to penalize the contractor (late to supply the required materials by tender or tender) the value of the fine due to the Irbid Electricity Company imposed by the Regulatory Authority of the Energy Sector as a result of the company's failure to comply with the required periods in executing the specified subscriber transactions Treatment is the delay of the supplier in the supply of material or materials necessary in the implementation of transactions subscribers.

## **Tendering Instructions**

1. The Tender shall be made in one copy of the accompanying form; however, all blanks and schedules shall be filled up in ink, and signed without alteration to the form of tender. If any such alteration were made, or if these Instructions were not fully complied with, the tender may be rejected. The tenderer; however, is at liberty to add any further details that he may deem desirable and, in the event of his so doing, shall print or type such details and annex the added matter to the tender submitted by him. Such additional details shall not be binding upon the purchaser unless they shall be subsequently incorporated in the contract.
2. One copy of the tender, and its accompanying documents, filled up as directed, together with the drawings, catalogs, and relevant documents called for, must be enclosed in a secure envelope endorsed (Tender for Contract) No. **(39/2022)** but bearing no other mark from which the identity of the tenderer can be ascertained.
3. All correspondences in connection with this tender and all matters accompanying the tender that are relevant to its examination shall be in English language and expressed in metric units.
4. The tender is to be held open for acceptance or rejection for a validity period of (120) days from the time fixed for opening the tenders.
5. Tenders received prior to the time fixed for opening of tenders will be securely kept, unopened. Tenders received after that time will be rejected. The purchaser bears no responsibility for premature opening of tenders not properly addressed or identified.
6. Tenders may be withdrawn by formal request received in writing from the tenderer prior to the time fixed for opening. If for any reason the tender should be withdrawn after the time fixed for opening and before expiry of the said validity period, the purchaser has the right to retain the full value of the tender bond.
7. The successful tenderer shall abide by the commercial and professional regulations as required by the Ministry of Industry & Trade, Engineering Association and other relevant Institutions in Jordan.
8. Tenderers attention is drawn to the action of customs officers in the discharge of their duties. Whereby air parcels are frequently opened In their own interests and in order to preserve the confidential nature of the tender price, tenderers are urged to pay attention to the:
  - a. To dispatch the completed tender document and any covering letter only by Air Mail which should be endorsed and labeled in the manner laid down in paragraph 10 of the Instructions to Tendering.
  - b. Technical literature and the like may reasonably be sent by Air Parcel or Air Freight but since this would then be separated from the actual Tender, each parcel should contain specific evidence identifying the Tender to which the contents refer.
  - c. The purchaser will not consider late or incompletely delivered tenders or literature supporting tenders due to the action of any customs officer.
9. In the event that the intending signatory does not manufacture one or more of the main sections of equipment and materials, then the tender submitted should give evidence to show that all the obligations imposed by the documents on the intending signatory have been fully understood

and accepted, where applicable, by the manufacturer(s) to whom it would be intended to sub-contract one or more of the main sections of the equipment and materials.

10. For overseas transport of the contractor and his Sub-contractors, suppliers and manufactures must give priority to Jordan shipping national lines, and to Arab shipping companies and their subsidiaries for the shipping of goods, materials provided such companies ships call at the port of export. The contractor shall also give priority to the Royal Jordanian Airlines for air freight shipment and transport of personnel.
11. Tenderer must submit country of origin and name of manufacturer for the offered goods.
12. The foreign bidders who participate in this tender must submit their bids through a registered local agent or through their registered office in Jordan.
13. For all manufacturers from inside Jordan it is quite essential that they have JQM for their products and the purchaser will have the right to accept or reject their offer if they did not submitted the JQM certificate with their offer.
14. If samples were not re-claimed by the tenderer within 60 days from date of order all samples shall remain the property of the purchaser.
15. The purchaser will not be responsible for, nor to pay for, any expenses or losses which may be incurred by a tenderer in the preparation of his tender.
16. If the tenderer has any doubt about the meaning of any portion of the General Conditions, Specifications, Drawings, he shall clarify such doubts before submitting his tender, or in case of any further information can be obtained by an application in writing to the director general.
17. Tenderers are particularly directed that the amount entered on the form of tender shall be a fixed price for performing the contract strictly in accordance with the bound document, and shall be the sum total of all the amounts printed into and entered by the tenderer upon the schedule of prices.
18. Tender price shall include all incidental and contingent expenses.
19. The tender shall be accompanied by a tender bond in the form of a Bank Guarantee valid for at least 120 days from the time fixed for the closing date of tender, or certified check in favor of and payable to the purchaser for a sum of.....as a guarantee of good faith. This bond is to be issued by any approved bank in Jordan. The bond will be returned to the unsuccessful tenderer within 120 days from the time fixed for opening the tenders or at such earlier time as a tender shall have been accepted by the purchaser. In the case of the successful tenderer, the bond will, subject to the conditions of contract, be returned as soon as a formal contract agreement and a performance bond have been entered into.
20. The successful tenderer have to submit a performance bond equal to (10) percent of the total amount of the order within (30) days from date of receipt of the order. Any delay will be subject to delay penalty. If the successful tenderer fails for any reason to submit the required performance bond within (30) days, the purchaser will confiscate the bid bond and the awarding letter will be cancelled too.

21. If the successful tenderer fails for any reason to submit the required performance bond within (30) days, the purchaser has the complete right to reserve the value of materials supplied, and payment will not release till the successful tenderer submit the required performance bond. And the bid bond will not return to the tenderer unless the performance bond shall submit to the purchaser according to tender conditions.
22. The performance bond should be valid for a period expiring at least one year after receipt of the last consignment in IDECO warehouse.
23. The tenderer shall state in his tender the name or names of the sureties, insurance company, or bank proposed for guaranteeing the performance of the contract.
24. Prices are highly recommended to be on the basis of C&F IDECO STORES. However C&F AQABA port or Amman customs are also accepted.
25. The tenderer may state the tender price in Jordanian Dinars. If however, a portion of the tenderer's expenditure under the contract is expected to be made in countries other than Jordan he may state a corresponding foreign currency portion of the tender price in the currencies of those other countries.
26. Stamp duty and award fees are payable on Jordanian contracts according to Jordanian laws and, after the placing of a contract, it is the contractor's responsibility to purchase legal stamps to the requisite amount depending on the contract value.
27. If after receipt of tenders, the purchaser finds any difference between prices shown on the form of tender in writing and in numerals, then the price shown in writing shall be considered correct by the purchaser and the tenderer. If any discrepancies are found between the total in the price schedule and the total obtained by adding the products of each quantity and its particular rate then, whether the price shown on the form of tender in numerals or in writing corresponds or not, the total obtained by adding the products of the quantities and their particular rates shall be considered by the purchaser and the tenderer as the tender price.
28. Tender revaluation will be consistent with the terms and conditions set forth in the tender document. In addition to the tender price adjusted to correct arithmetical errors, other relevant factors such as the time of completion of delivery or construction, operating costs where applicable, or the efficiency and compatibility of the equipment, the availability of service and spare parts, and reliability of construction methods proposed will be taken into consideration, to the extent and in the manner specified in the tender documents, in determining the evaluated tender most advantageous to the purchaser. For comparison of all tenders, the currency or currencies of the tender price for each tender will be valued in terms of Jordanian Dinars. The rates of exchange to be used in such valuation will be the selling rates published by the central bank of Jordan and applicable to similar transactions, on the day tenders are opened unless there should be a change in the value of the currencies before the award is made. In the latter case, the exchange rates prevailing at the time of the decision to notify the award to the successful tenderer may be used.
- 29. The purchaser does not bind himself to accept the lowest or any tender, nor to assign any reason for the rejection of any tender, nor to purchase the whole of the equipment and materials specified. The purchaser has the right to purchase part of the tender, even if it is only one item from the schedule of rates and prices.**
30. The tenderer shall submit with his tender in order of the relevant clauses, a statement of any departures from specifications, or he can fill in the related schedule attached herewith.

Notwithstanding any description, drawings, or literature which may be submitted, all details other than those in the statement of departures shall be assumed to be in accordance with the specification.

- 31.**The successful tenderer have to submit a performance bond equal to (10) percent of the total amount of the order within (30) days from date of receipt of the order. Any delay will be subject to delay penalty. If the successful tenderer fails for any reason to submit the required performance bond within (30) days, the purchaser will confiscate the bid bond and the awarding letter will be cancelled too.
- 32.**Although IEC standards for workmanship, equipment and materials, have been selected in this specification as a basis of reference, standards and specifications of other countries and recommendations of other international standard organizations will be acceptable provided that they are substantially equivalent to the designated standards and provided further that the tenderer submits for approval detailed specification which he proposes to use.
- 33.**References to brand names or catalog numbers, if any, in this specification have been made only for that equipment for which it has been determined that a degree of standardization is necessary to maintain certain essential features. In certain instances such references have also been made for purpose of convenience to specify the requirements. In either case offers of alternative goods which have similar characteristics and provide performance and quality at least equal to those specified are acceptable.
- 34.**Where compliance with a specific standard specification is called for the standard specification used shall be that in force at the time of tender.

## **General Requirements Standards and Regulations**

- The following general requirements will apply, in so far as they may be applicable, to material to be supplied under this particular contract.

### **1. Design and Construction:**

In complying with the requirements of the specification both with respect to arrangement and detail, design is to conform to the best current engineering practice. Each of the several parts of the material is to be of the maker's standard design provided that this design is in general accordance with the specification.

The essence of design should be simplicity and reliability in order to give long continuous service with high economy and low maintenance cost. Particular attention should be paid to internal and external access in order to facilitate inspection, cleaning and maintenance. The design dimensions and materials of all parts are to be such that they will not suffer damage as a result of stresses under the most severe conditions. Fully detailed specifications of the several parts of the material are to be submitted describing particularly the materials to be used. The materials used in the construction of the material are to be of the highest quality and selected particularly to meet the duties required of them. Mechanisms are to be constructed to avoid sticking due to rust or corrosion. Workmanship and general finish are to be of the highest class throughout. All similar parts of the material are to be interchangeable.

All equipment is to operate without undue vibration and with the least possible amount of noise and is not to cause a nuisance. All equipment is to be designed to minimize the risk of fire and any damage, which may be caused in the event of fire.

The equipment is also to be designed to prevent ingress of all vermin, accidental contact with live parts and to minimize the ingress of dust and dirt. The use of materials, which may be liable to attack by termites or other insects, is to be avoided.

### **2. Compliance with Standards:**

Although the standards for workmanship, material, and equipment have been selected in these specifications as a basis of reference, standards and specifications of the other bank member countries and recommendations of standards international organizations will be acceptable provided they are substantially equivalent to the designated standards and provided furthermore that the contractor submits for approval detailed specifications which he proposes to use. Reference to brand names or catalog numbers if any in these specifications have been made only for that equipment for which it has been determined that a degree of standardization is necessary to maintain certain essential features. And in certain cases such references have also been made for purposes of convenience to specify the requirements, in either case offers of alternative goods, which have similar characteristics and provide performance and quality at least equal to those specified are acceptable. If the contractor offers materials, equipment, design calculations or tests, which conform to standards other than those specified, full details of the differences between the proposed standards and that specified in so far as they affect the design or purpose of the equipment, are to be supplied by the contractor if called upon to do so by the engineer, where required by the engineer for approval purposes, the contractor shall supply, without charge, duplicate copies of the proposed standards with English translations of the relevant portions. The contractor shall have available in his place of business (or in his supplier's works) the relevant copies of standards or codes used for the use of the Engineer.

### **3. Statutory Regulations**

The materials, equipments and instruments forming part of this contract are to comply in all respect with any relevant local statutory regulations, by laws & orders currently in force.

### **4. Language**

English language shall be used in all documents contained in the tender and in all correspondence between the contractor and engineer. Whenever any thing is required under the terms of the contract to be written marked, printed or engraved, the English language shall be used and duplicated in Arabic except where otherwise provided in this specification.

### **5. Correspondences**

All correspondences on matters arising out of the contract shall be addressed by the contractor to Engineer and not directly to but copied to the purchaser.

### **7. Units of Measurement**

In all correspondence, in all technical schedules, on all drawings and for all instrument scales, SI units of measurement are to be employed. On drawings where IEC or other units have been used it will be in order if the equivalent SI measurement is suitably marked in addition.

### **8. Contractor's Responsibilities**

Unless stated specifically to the contrary in the tender with full supporting explanations, the contractor will be deemed to have concurred as a practical manufacturer with the design and layout of the works as being sufficient to ensure reliability and safety in operation, freedom from undue stresses and satisfactory performance in all other essentials as a working material.

### **9. Compliance with Specification**

Notwithstanding any descriptions, drawings or illustrations which may have been submitted with the tender, all details other than those shown on the schedule of departures will be deemed to be in accordance with the specification and the standard specification and codes referred to therein.

No departures from the specification except those shown on the schedule of departures and approved by the purchaser are to be made without the written approval of the Engineer.

### **10. Drawings and catalogues**

The Tenderer must submit with his offer all the specification indicating rating, weights, and dimension and time current characteristics of the offered materials.

Before the work is put in hand, dimensioned drawings and diagrams showing all details of the material, and materials to be used are to be submitted to the engineer for approval.

No wiring or connection diagrams shall be submitted for approval unless prior approval has been obtained for schematic diagrams, which are to include control and protection schematics showing the facilities being provided and the working of the schemes.

The drawings are to be submitted in quadruplicate and as soon as possible after the commencement date of the contract, and in any case in sufficient time to permit modifications to be made, if such deemed necessary by the Engineer without delay in the delivery of the contract work. The drawings submitted are to be modified as necessary if requested by the Engineer and resubmitted for final approval. If the contractor requires urgent approval of any drawing to avoid delay in the delivery of the contract works, he is to advise the Engineer accordingly when submitting the drawing. One copy of each drawing and diagram shall be sent direct to the purchaser. It is to be understood, however, that approval of the drawings will not exonerate the contractor from any responsibility in connection with the work. After all items of material have been manufactured and accepted three 35mm negatives of each drawing previously approved

is to be provided together with one reproducible on gauge polyester base film or similar and two prints on heavy gauge white paper from such drawings as may be required to show the detail and arrangement of the material as made. All drawings submitted by the contractor or by any sub contractor are to have the following particulars in the lower right hand corner in addition to the contractor's name:

**IRBID DISTRICT ELECTRICITY COMPANY, CONTRACT NUMBER (39/2022).**

## **11. Program of work**

Within one month of acceptance of the tender, the contractor is to forward to the engineer four copies of chart detailing the material manufacture and delivery Program for the complete contract work for his comment or approval. Copies of the approved chart, as required by the engineer, are to be provided by the contractor. The chart is to indicate the various phases of work for all items of the contractor from the commencement of the contract to its final completion, e.g. design, ordering, of materials, manufacture and delivery. If at any time during the execution of the contract it is found necessary to modify the approved chart, the contractor is to inform the engineer and submit a modified chart for approval. Such approval is not to be deemed to be consent to any amendment of the completion date stated in the schedule.

## **12. Progress Report and Meetings**

### **a. Progress Reports**

At monthly intervals after approval of the Program chart, the contractor is to submit to the Engineer and the purchaser written detailed progress reports in triplicate in an approved form, indicating the stage reached in the design, ordering of material, manufacture and delivery of all components of the material. The reports should include details of any delays and the remedial action proposed. These reports are to be forwarded promptly so that on receipt by the engineer the information contained therein is not more than seven days out of date.

### **b. Meeting:**

If during the execution of the contract the Engineer considers the progress position of any section of the work to be unsatisfactory, he will be at liberty to call such meetings, either in Irbid office, or at the contractor's work, as he deems to be necessary. If required by the Engineer a responsible representative from the contractor's works is to attend such meetings. Access to the contractors and sub-contractor's works is to be granted to the engineer at all reasonable times for the purpose of ascertaining progress.

## **13. Packing**

Each item to be packed properly or protected for shipment and be capable of sustaining heavy handling during transportation from the place of manufacture to the purchasers stores in Irbid and hence to site and to be suitable for storage for a period of 6 to 12 months after to site.

Tube ends and other similar open ends are to be protected from both external damage and ingress of dirt and moisture during transit and while at purchaser's stores. Flanged pipes are to have their open ends protected by adhesive tape or jointing and then be covered with a wooden blank flange secured by service bolts. Precautions are to be taken to protect shafts and journals where they rest on wooden or other supports likely to contain moisture. At such points, wrappings impregnated with anti-rust composition or vapor phase inhibitors are to be used with sufficient strength to resist chafing and indentation due to movement which is likely to occur in transit. Protective wrappings and impregnation are to be suitable for a period of three months. In the case of ball or roller bearings installed in any items of material, precautions are to be taken to avoid indentation of the bearing races.



Metal bindings of cases are to be of corrosion resistant material position with struts or cross battens and not with wood chocks wedged in place, unless they are fastened firmly in place. All struts or cross battens are preferably to be supported by cleats fixed to the case above and below to form ledges on which the batten may rest. Cases are to be unopened after packing to prove that there is no movement of contents.

Where parts are required to be bolted to the sides of the case, large washers are to be used to distribute the pressure and the timber is to be strengthened by means of a pad.

Where practicable, all indoor items such as electric motors, switch and control gear, instruments and panels, machine components, etc., are to be cocooned or covered in polyethylene sheeting, sealed at the joints and the enclosure provided internally with a desiccators. Each crate or package is to contain a packing list in a waterproof envelope. All items of material are to be clearly marked for easy identification against the packing list. All cases, packages, etc. are to be clearly marked on the outside to indicate the total weight, to show where the weight is bearing and the correct position of the slings and are to bear an identification mark relating them to the appropriate shipping documents. Stencil marks on the outside of casings are to be indelible. The Engineer may require inspecting and approving the packing before the items are dispatched but the contractor is to be entirely responsible for ensuring that the packing is suitable for transit and such inspection will not exonerate the contractor from any loss or damage due the faulty packing.

# Inspection and Testing

## 1. **General Requirement**

The whole of the material by the contract will be subject to inspection and testing by the engineer during manufacture and on completion. The approval of the engineer or the passing of any such inspection or test will no, however; prejudice the right of the purchaser to reject the material if it fails to comply with the specification when erected or to give complete satisfaction in service. The costs of all tests and inspection shall be borne by the contractor and shall be deemed to be included in the contract price. Before any material is packed or dispatched from the main or sub-contractor's works, all tests called for are to have been successfully carried out in presence of the engineer.

Adequate notice shall be given when the material is ready for inspection or test and every facility shall be provided by the contractor and his inspection and his sub-contractors to enable the Engineer to carry out the necessary inspections and tests.

Triplicate copies of all principal test records and test certificates shall be supplied to the Engineer for all tests carried out in accordance with the provisions of the contract.

## 2. **Sub-Contractors**

Within two months of acceptance of the tenders the contractor shall forward to the engineer a list of all sub-orders placed or intended. The contractor shall submit three copies of all sub-orders or selected by the engineer for progress or inspection. One copy of all drawings referred to in the sub-order is to be submitted unless otherwise agreed by the engineer. The drawings and sub-orders submitted to the engineer will cover all major components which are subject to electrical and mechanical pressure or stress when the material is in operation and also auxiliaries and stores which will be dispatched to site direct from the sub-contractor's work. For the purpose of this clause inter-works orders are to be treated as sub-order. Sub-orders are to include a statement advising the sub-contractor that the items being order will be subject to inspection and test by the Engineer. It is important that all copies of such orders are clearly marked with the main contractor's name and the following reference:

**IRBID DISTRICT ELECTRICITY Co. CONTRACT No. (39/2022).**

Sub-Contractors are to comply with all the applicable requirements of this specification. Orders issued by the sub-contractor are also to include the main contractor's reference on their sub-order in addition to the above-mentioned heading.

## 3. **Material Tests**

The contractor shall provide test prices as required by the engineer to enable him to determine the quality of the material supplied free of charge and any cost of the tests shall be borne by the contractor. If any test pieces fails to comply with the requirements of the appropriate specifications for the material in question, the engineer may reject the whole of the material represented by that piece, the contractor's designers and metallurgists will be consulted before any material is so rejected. In the event of the engineer being furnished with the certified particulars of the tests which have been carried out for the contractor by the suppliers of the material, he may, at his own discretion, dispense with the previously mentioned tests entirely.

## 4. **Tests at Manufacture's Works**

Works tests shall include all routine, electrical, mechanical and hydraulic tests in accordance with the relevant IEC standard or other standard may be approved except where departures there from and modifications thereto are embodied in this specification. For material not covered by an IEC or British standard or specifically mentioned in this specification the tests shall be

agreed with the Engineer. After satisfactory completion of the witnessed tests at the works, the material shall be submitted for the engineer's approval preparatory to shipping. No item of material is to be dispatched to site until the Engineer has given his approval in writing.

#### **5. Test Certificates**

Triplicate sets of all principal test records test certificates and performance curves shall be supplied for all tests carried out in accordance with the provisions of this contract. These test records, certificates and performance curves shall be supplied for all tests, whether or not they have been witnessed by the engineer. The information given in such test certificates and curves shall be sufficient to identify the material or equipment to which the certificates refers and should also bear the contract reference and heading as given in clause 7.2 of this section.

#### **6. Rejection of Plant**

IF Any item of material or component which fails comply with the requirements of this specification in any respect whatsoever at any stage of manufacture, test, erection or on completion at site may be rejected by the engineer either in whole or in part as he considers necessary, and after adjustment or modification if so directed by the Engineer, the contractor shall submit the item for the item for the further inspection and / or test. In the event defects of such a nature that the requirements of this specification cannot be fulfilled by adjustment or modification shall be replaced by the contractor, at his own expense, to the entire satisfaction of the engineer.

#### **7. Maintenance**

The contractor is to guarantee the efficient and good working of the material supplied under the contract for a period of twelve months (Gregorian) from the date of delivery of the material to Irbid, in accordance with the General conditions of contract.

#### **8. Tests**

All tests meet the requirements of latest international standard mentioned in the contract or any relevant standard.

**Irbid District Electricity Co.**

**Form of Bid Bond**

**Tender No. (39 /2022)**

Dear Sir,

We are pleased to inform you that we guarantee M/S.....for the amount of.....in order to allow them to submit an offer for the due performance of the undertaking and obligation as specified in their Tender for Contract No. ....This Guarantee shall remain valid for a period of one hundred twenty days from the time fixed for opening the Tenders by IRBID DISTRICT ELECTRICITY CO. LTD.

This Guarantee shall be free from any interest and will be extended or paid in cash upon your first request in any or required, without the need for natural warning or judicial proceedings and without any rights to delay, oppose, or stop payment on our part, or on the part of the Tenderer or any of his representatives whom over. This Guarantee shall be deemed valid until the submittal of a duly executed Performance Bond.

Signed.....Bank

(Surety)

**Irbid District Electricity Co. Ltd.**

**Form of Performance Bond**

**Tender No. (39 /2022)**

Dear Sirs,

At the request of.....bank (the Foreign Bank) and on behalf of M/S..... Contractor's Name and Address), we..... Bank (the Local Bank) issue in your favor our irrevocable and unconditional Performance Bond No.....in the amount of .....(In word), in this connection we ..... Bank (the Local Bank) hereby consider ourselves responsible forth unconditional payment to you or to your authorized representatives of the above sum on your first written demand in whole or in part notwithstanding any objections on the part of the above named contractor and without any need for natural warning or judicial proceedings.

This Bond will expire on ..... and shall be renewed automatically for a period of ..... months and for consecutive similar periods until it is returned by you to us.

**Signed .....** **Bank**

**(Surety)**

# Technical specification

## 1. Climate Conditions:

The following is applicable unless otherwise is mentioned:

- |    |  |  |
|----|--|--|
| a. | Maximum Ambient Temperature                        | 50 C°  |
| b. | Minimum Ambient Temperature                        | -10 C°   |
| c. | Design temperature                                 | 45 C°  |
| d. | Maximum daily range of air temperature             | 20 C°  |
| e. | Maximum Wind Pressure                              | 420 n/m <sup>2</sup>   |
| f. | Ice Thickness                                      | 10 mm.   |
| g. | Snow Falls   | 1-4 days – 30 cm.  |
| h. | Site altitude                                      | 0-1400m ASL  |
| i. | Average annual rainfall                            | 40cm during November–April   |
| j. | Relative humidity in the range                     | 30 to 60%.   |
| k. | Average number of thunder storms                   | 15 days / year   |
| l. | Prevailing wind winter average daily approximately | 5-8 m/s, with gust up to 30 m/s.   |
| m. | Summer wind average afternoon                      | 10-13 m/s, during morning generally light and variable, gust speed up to 30 m/s. |

2. **General Description:** Tubular steel poles being supplied shall be used as supports for carrying Medium Voltage, Overhead electric network conductors.

3. **Applicable Standards** that shall be followed as minimum requirements accordance to until unless otherwise is mentioned: A53/A 53M-(2012 or last version), Grade B for MV Poles. -Grade of steel used St52-3 or equivalent standard.

## 4. The following shall be tested, based on the above standards:

- a. Materials and Manufacturers
- b. Chemical Composition
- c. Product Analysis
- d. Mechanical Properties
- e. Galvanization Process
- f. Product Marking
- g. Supplementary Requirements (Flattening test, Effective area, Yield strength, Tensile strength, Elongation %).
- h. Deflection test.
- i. Drop test

5. **Galvanization Process** the weight per unit area of zinc coating shall be not less than (0.55kg/m<sup>2</sup>) as determined from the average results of the two specimens taken for test in the manner prescribed in 17-1 to 17-7 that is given the standard A53/A 53M-(2012 or last version), for welded steel hot – dipped galvanized and without any defects.

**6. Dimensions and Weights** for pipes used in manufacturing Medium Voltage poles according to A53/A 53M-(2012 or last version), Grade-B

Nominal Size(Inch)	Wall thickness	Weight (kg/m)	Outside Diameter
6	5.56	22.31	168.3
7	6	27.6	193
8	6.35	33.31	219.1

**7. MV Poles Construction:**

No	Net Pole Length (m)	Pole Part (1)	Pole Part (2)	Pole Part (3)
1	17	10m length, Pipe diameter 8 Inches, 6.35mm, wall thickness <u>overlap between 8" &amp; 7" (0.5m)</u>	5 m length, Pipe diameter 7", wall thickness 6mm, <u>overlap between 7" &amp; 6" (0.5m)</u>	3m length, Pipe diameter 6", wall thickness 5.56mm
2	15	7.5m length, Pipe diameter 8", wall thickness 6.35mm <u>overlap between 8" &amp; 7" (0.5m)</u>	5.5m length, Pipe diameter 7", wall thickness 6mm <u>overlap between 7" &amp; 6" (0.5m)</u>	3m length, Pipe diameter 6", wall thickness 5.56mm
3	14	7.5m length, Pipe diameter 8", wall thickness 6.35mm, <u>overlap between 8" &amp; 7" (0.5m)</u>	4.5m length, Pipe diameter 7", wall thickness 6mm, <u>overlap between 7" &amp; 6" (0.5m)</u>	3m length, Pipe diameter 6", wall thickness 5.56mm
5	12	7.5m length, Pipe diameter 8", wall thickness 6.35mm <u>overlap between 8" &amp; 7" (0.5m)</u>	2.5m length, Pipe diameter 7", wall thickness 6mm <u>overlap between 7" &amp; 6" (0.5m)</u>	3m length, Pipe diameter 6", wall thickness 5.56mm
7	10	7.5m length, Pipe diameter 8", wall thickness 6.35mm <u>overlap between 8" &amp; 7" (0.5m)</u>	3m length, Pipe diameter 7", wall thickness 6mm	NA

## 8. materials:

- a) Minimum grade of steel MV poles ST having a tensile strength not less than 520 N/mm<sup>2</sup>. (IDECO requirement used St52-3 or equivalent standard)
- b) Structural steel for top cap shall be hot galvanized minimum thickness 2 mm, welded around and painted silver colour.
- c) Fully galvanized after fabrication for poles. (as an option).
- d) All poles (galvanization layer) after the production shall be free of any defects during SWAGED.
- e) the breaking load of the pole shall be as the below table: -

length of the pole	17	15	14	12	10
Planting depth (m)	2.30	1.80	1.80	1.80	1.50
breaking load (kgf)	746.02	825.39	888.39	1048.46	1307.63

- f) type of pole: swaged type
- g) Red paint mark at a height of 3 meters from the bottom of the pole, 2 cm wide
- h) Point of application of load top: 10 cm
- i) the Circular hole as drawing no.6:
  - A - (22 mm)- for upper circular holes.
  - B - (14 mm)- for bottom circular hole.

## 9. Manufacturing of galvanized Tubular steel pole:

- a) All joints shall be cold swaged together and bevelled on the outside to form water shed; also the end of swaged portion shall be welded around the next portion.
- b) If the tube section joints are cut and welded, a true fit spacer ring should be installed to add LATERAL support.
- c) **Welding steel stripes (150 mm × 60mm × 6 mm ×3) for each overlap after reduced pipe and welding ( as an option, IDECO has the right to require those strips in case the quality of welding does not comply with IDECO requirement.)**
- d) **For option no. 2, the manufacturer shall clean and scrape the internal weld line of the pipe with distance not less than 60 cm.**

## 10. Tolerance:

after the poles were manufactured completely, the following tolerances shall be tested by the engineer:

1. The maximum deviation from straightness should not exceed 0.001 of the overall length at the pole, measured when the pole is lying horizontally in the unloaded state.
2. Tube circumference as per A53/A 53M-(2012 or last version), Grade B
3. Tube diameter as per A53/A 53M-(2012 or last version), Grade B
4. Over length tolerance FOR POLS + 0.001% of overall length

## 11. Quality control:

poles shall be finished cleanly free from harmful defects and reasonably free from scale.

- a) Drawing (1-5): below pole length of (17,15,14,12 and 10) meters
- b) Circular hole on poles shall be punched as drawing no. 6

## 12. Weight tolerances:

in case the required poles were within the tolerances of A53/A 53M-2012 and their weight is less than the weight described earlier, then more poles shall be offered to meet the required weight for poles.

## 13. Inspection:

The contractor shall to submit with his offer the cost of routine tests of the required materials as per A53/A 53M--(2012 or last version) or related standard conducted in Jordanian royal scientific (JRS), and IDECO has the right to perform these tests in (JRS), or not.

## 14. IDECO SPECIAL REQUIRMENT

**\*\* Grade of steel used St52-3 of a minimum tensile strength  $\geq 520$  N/mm<sup>2</sup>.**



**Drawing no.1 - Steel Tubular Specification 17 Meter.**

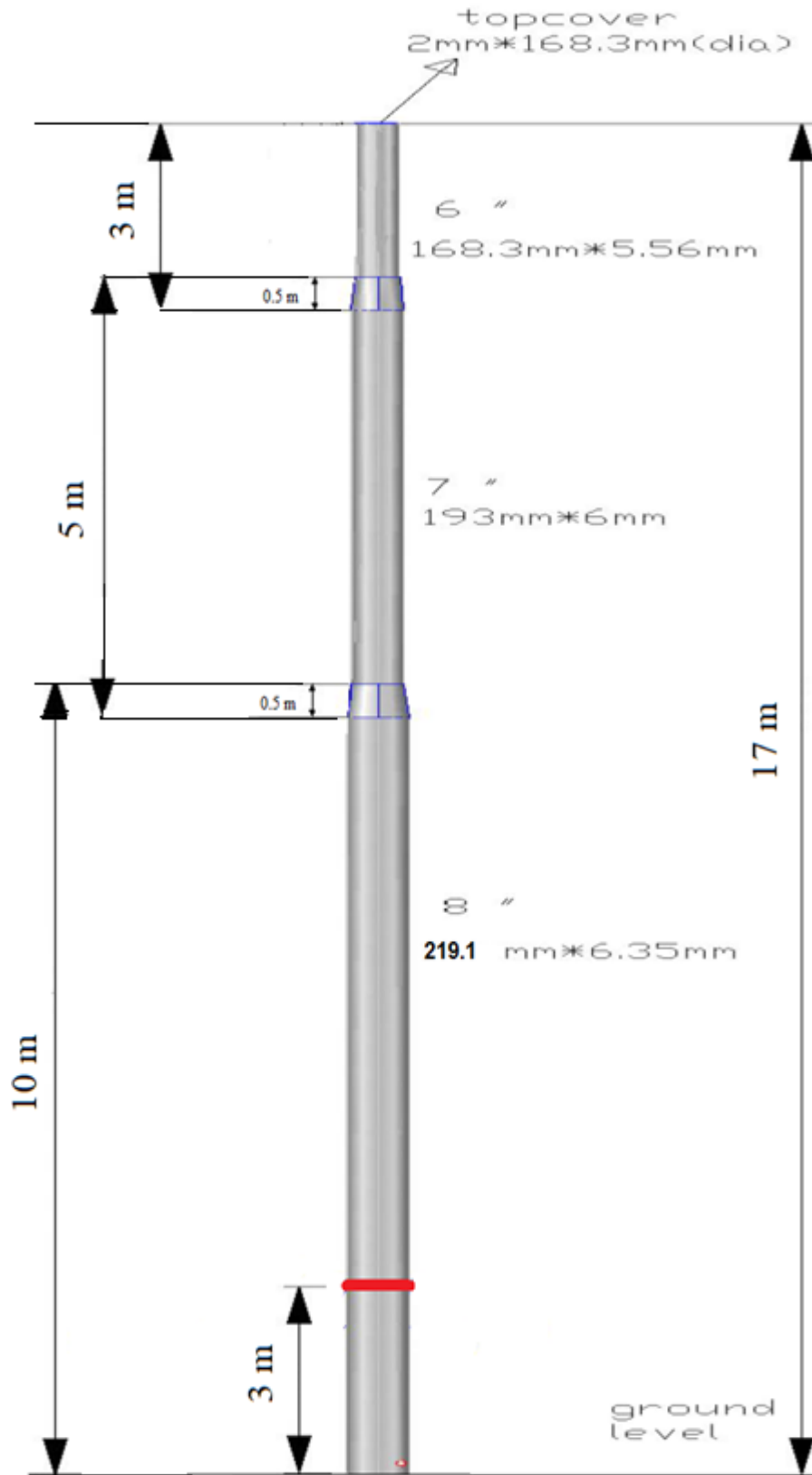

**Drawing no.2 - Steel Tubular Specification 15 Meter.**

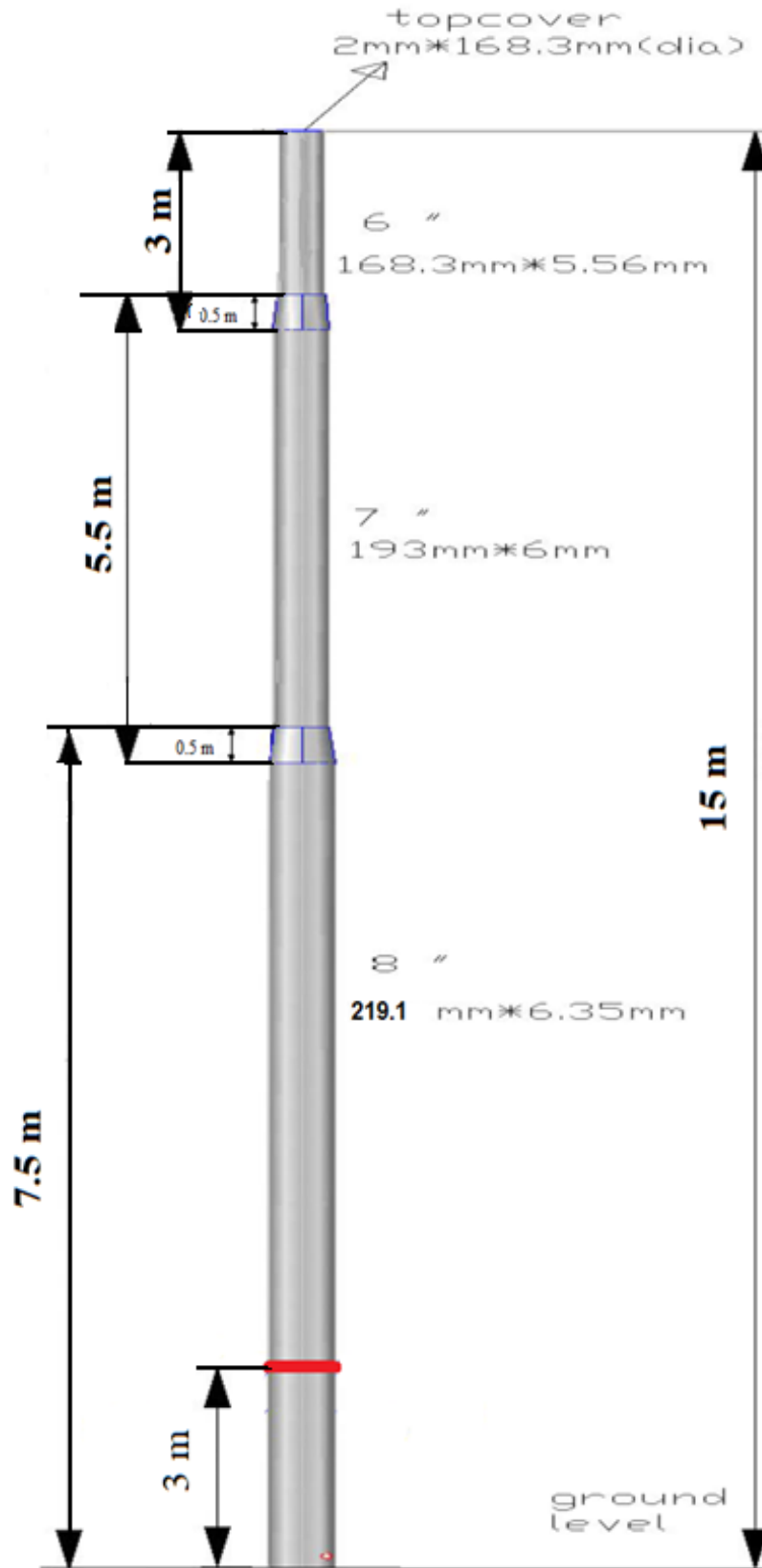

### Drawing no.3 - Steel Tubular Specification 14 Meter.

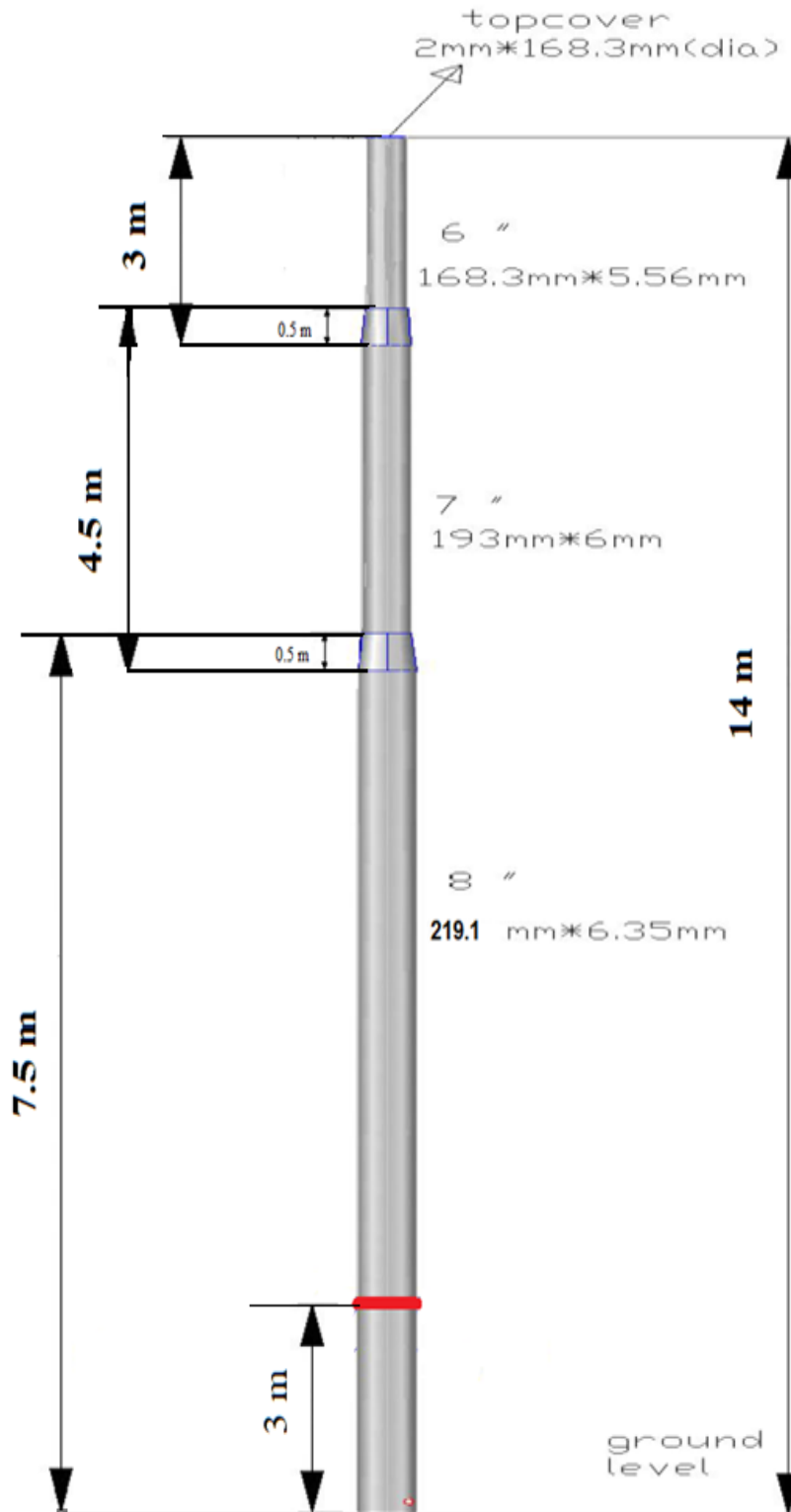

**Drawing no.4 - Steel Tubular Specification 12 Meter.**

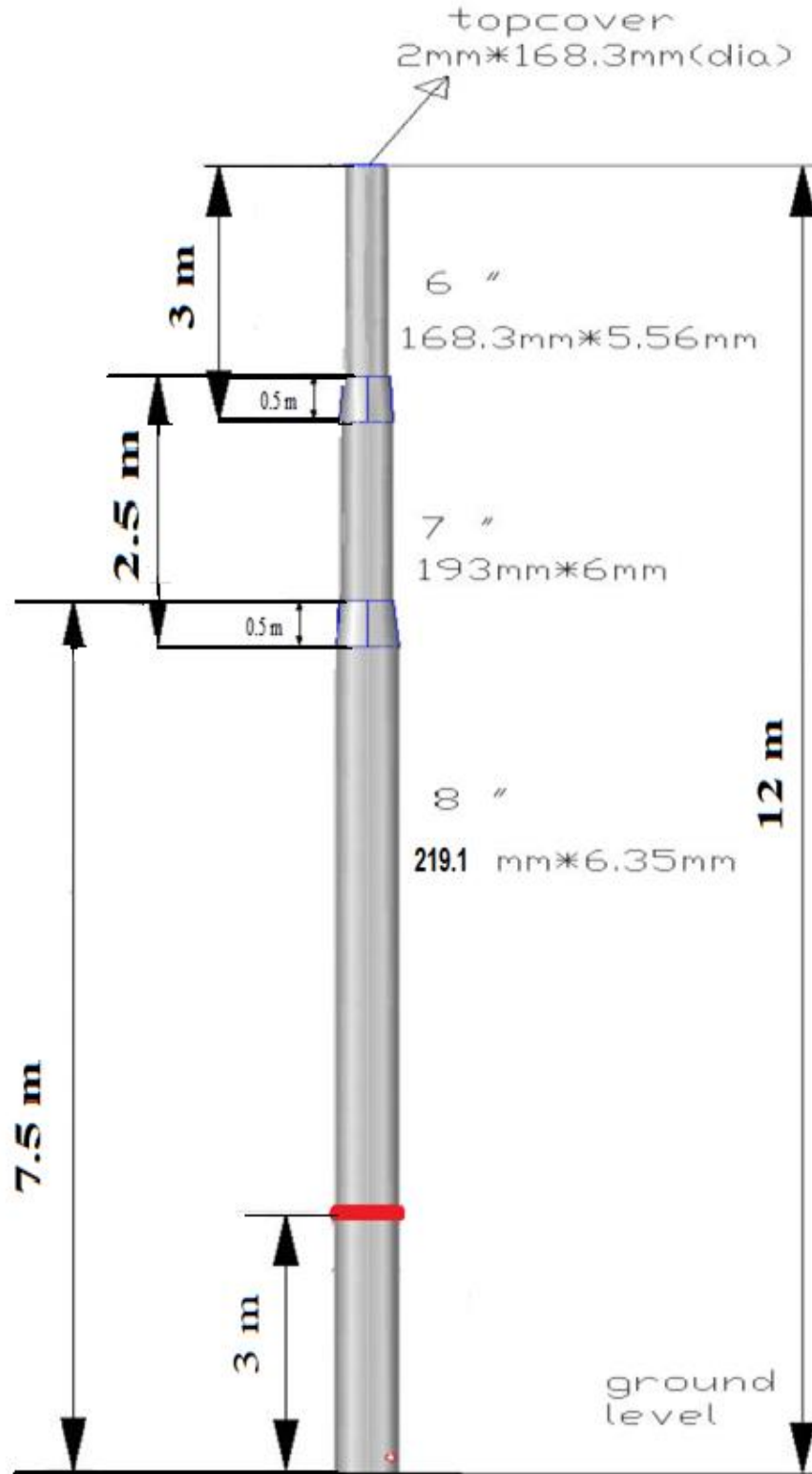

**Drawing no.5 - Steel Tubular Specification 10 Meter.**

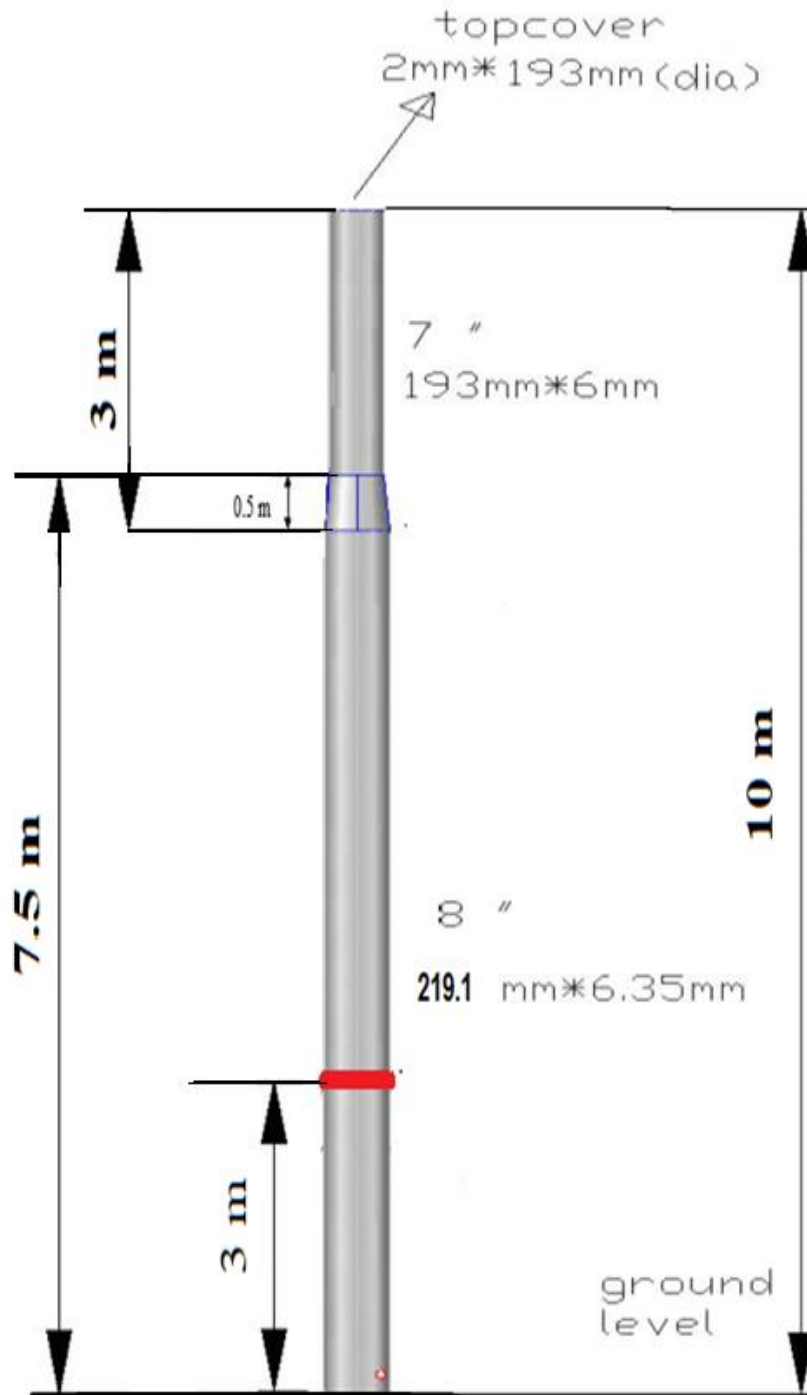

## Drawing no.6- Steel Tubular Specification / Circular hole

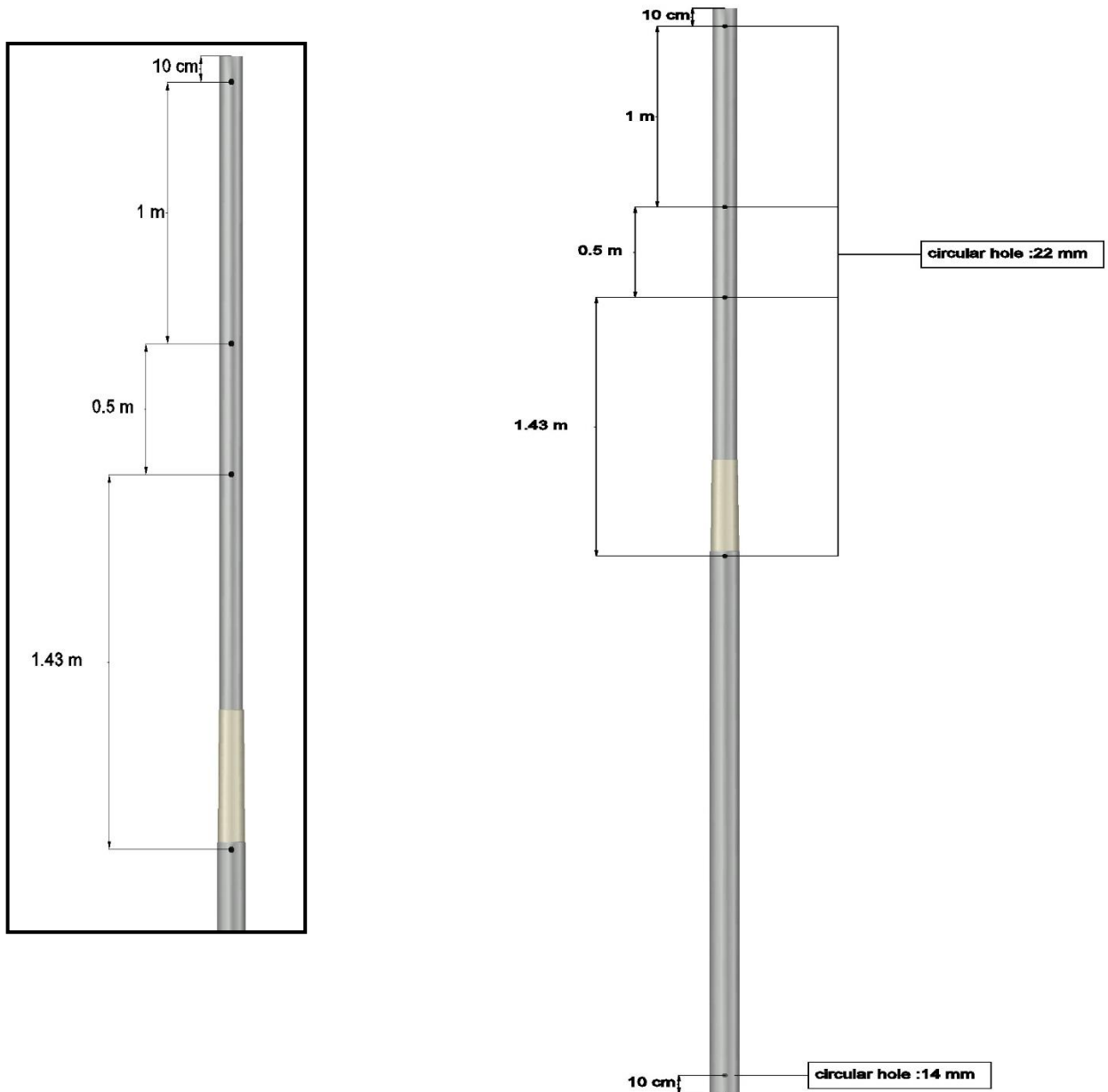

**Type of pole:** swaged type.

**Overall length:** (17,15,14,12 and 10) meter.

**Planting depth:** Depends on the length of the pole - (2.3,1.8, and 1.5) meter

**Red paint mark** at a height of 3 meters from the bottom of the pole, 2 cm wide

**Point of application of load top:** 10 cm.

**Steel minimum tensile strength** 520 N/mm<sup>2</sup>

**Circular hole:** A - (22 mm)- for upper circular holes.

B - (14 mm)- for bottom circular hole.

## Special Requirements

- The Below mentioned requirements shall have a precedence in all of the preceding specifications and requirements, and the tenderer is kindly requested to strictly follow.
1. The manufacturer shall to print IDECO Contract No. **(39/2022)**, and country of origin along with the stock code corresponding to the certain material as seen in the invitation to tender table page 3.
  2. Maintenance instructions: Where the equipments / materials supplied are subject to maintenance during service the manufacturer shall submit for approval a draft of the recommended maintenance instructions. After approval the supplier shall supply any further copies required by the Engineer. These maintenance instructions shall be provided before the taking over of any part of the equipment.
  3. The manufacturer shall to submit with his offer reference list for his products for last five years ago.
  4. Each shipment of the required materials shall be inspected by two IDECO engineers during manufacturing in country of origin, and all related inspection cost (Visa, Air Tickets, Hotel, Accommodation, Transportation, etc.) Shall be borne by contractor.
  5. The required materials shall be delivered to IDECO stores by trucks without sides or open top container, otherwise the contractor shall be imposed to do unloading the materials by himself, or bear the full financial costs of any defects of materials during the unloading.
  6. **Weight tolerances**: in case the required poles were within the tolerances of **A53/A 53M-2012** and their weight is less than the weight described earlier, then more poles shall be offered to meet the required weight for poles.
  7. The contractor shall have calibrated equipment's by authorized party for inspection purposes.
  8. **Inspection**: The contractor shall to submit with his offer the cost of routine tests of the required materials as per **A53/A 53M-2012** or related standard conducted in Jordanian royal scientific (JRS), and IDECO has the right to perform these tests in (JRS), or not.
  9. The contractor shall nominate third party laboratory and cost of inspection by third party as shown in **Schedule No. 5**, in case the attendance of ideco engineers is not applicable due to any reason.
  10. The contractor shall issue maintenance warrantee for 15 months.
  11. The technical drawing approval if required shall be submitted during 7 days from order letter.
  12. After Awarding Tenders, winner tenderer will be assessment according to quality of good, delivery period, service after sale, and assessment weight will be considered in coming tenders' evaluation.
  13. Euro one certificate shall be submitted during clearance process, in case the country of origin of the required materials from Europe countries.
  14. The supplier shall accept partial order.
  15. **QR code contain the following message shall be engraved on nameplate of poles at height of 3 meter from the bottom.**

**IDECO Tender No. 39 /2019 - Stock code xxxx xxxxx as mentioned in table 1, Serial number, Manufacturer name, Manufacturing date.**

### Delivery Period Table (3)

The Supplier shall obligate to deliver the required poles in partial shipments to be three shipments, and the preferred delivery period for the required shipment as explain in the schedule below:

Table No.3.

No.	Material	Quantity	First Shipment Delivery shall be During 3 months from order letter.	Second shipment Delivery shall be at 15/04/2023	Third shipment Delivery shall be at 15/08/2023
1	Medium Voltage, 17m length, Galvanized Steel poles , consist of 8" & 7" &6" pipes according to A53/A 53M-2012, Grade B.	1000	500	250	250
2	Medium Voltage, 15m length, Galvanized Steel poles , consist of 8" & 7" &6" pipes according to A53/A 53M-2012, Grade B.	1100	500	250	350
3	Medium Voltage, 14m length, galvanized Steel poles consist of 8" & 7" &6" pipes according to A53/A 53M-2012, Grade B.	50	50	0	0
4	Medium Voltage, 12m length, galvanized Steel poles, consist of 8" & 7" &6" pipes, according to A53/A 53M-2012, Grade B.	130	130	0	0
5	Medium Voltage, 10m length, galvanized Steel poles, consist of 8" & 7" pipes, according to ASTM A53/A 53M-2012, Grade B.	510	250	260	0



### Schedule (1)

#### Departures from Technical Specifications, General Condition and Special Requirements

➤ The Tenderer is kindly requested to fill in the below schedule if applicable:

No.	Required Specification	Departure
1		
2		
3		
4		
5		
6		

**Remarks:**

- ❖ ...
- ❖ ...
- ❖ ...

**Schedule (2)**  
**Manufacturing and Testing**

- This schedule shall be completed by the tenderer, and the periods entered shall be binding on the contractor, its essential that the overall period for completion of the contract is adhered to and the program shall be formulated accordingly. All periods entered below are to be in weeks, and related to the placing of the contract.

No.	Material	Manufacturer	Manufacturing Place	Manufacturing period	Place of Testing
1	Medium Voltage, <b>12.5m</b> length, Galvanized Steel poles , consist of 8" & 7" pipes ( pole part (1) & pole part (2) of <b>15m</b> pole ) according to A53/A 53M-2012, Grade B.				
2	Medium Voltage, <b>11.5m</b> length, galvanized Steel poles, consist of 8" & 7" pipes ( pole part (1) & pole part (2) of <b>14m</b> pole ) according to A53/A 53M-2012, Grade B.				
3	Medium Voltage, <b>12m</b> length, galvanized Steel poles, consist of 8" & 7" & 6" pipes, according to A53/A 53M-2012, Grade B.				
4	Medium Voltage, <b>10m</b> length, galvanized Steel poles, consist of 8" & 7" pipes, according to ASTM A53/A 53M-2012, Grade B.				
5	Medium Voltage, <b>7.5m</b> length, Galvanized Steel poles , consist of 7" & 6" pipes ( pole part (2) & pole part (3) of <b>17m</b> pole ) according to A53/A 53M-2012, Grade B.				
6	<b>8 Inches</b> , 10m length, 6.35mm wall thickness, 33.31 kG/m, outside diameter 219.1mm, Hot Dipped Galvanized Steel tubes, according to ASTM A53/A53M-2012, Grade B, for the use in Medium Voltage networks.				
7	<b>6 Inches</b> , 3.0m length, 5.56mm wall thickness, 22.31 kG/m, outside diameter 168.3mm, Hot Dipped Galvanized Steel tubes, according to ASTM A53/A53M-2012, Grade B, for the use in Medium Voltage networks.				

### Schedule (3) Price Summary (option (1)).

- **This schedule price if the contractor can ship poles of 17m, 15 m and 14m as one piece, and able to transport those pole by sea to Aqaba Port or to IDECO store.**
- The tenderer shall enter in the appropriate columns of this schedule the prices at which each item will be supplied. Prices shall include shipment and delivery to the selected destination seen below based on the following selected transportation obligations.
- IDECO Company is not exempted from custom duties, sales taxes, import license fees and any other tariffs.
- Delivery period shall be expressed **in weeks**; it's recommended to start from the order awarding date. Transportation obligations shall be indicated as below:
  - ( ) CFR - Aqaba Port      ( ) CPT- Amman Customs      ( ) CPT- IDECO Stores

No.	Quantity Pcs	Material	currency	Unit Price	Total Price
1	1000	Medium Voltage, 17m length, Galvanized Steel poles , consist of 8" & 7" &6" pipes according to A53/A 53M-2012, Grade B.			
2	1100	Medium Voltage, 15m length, Galvanized Steel poles , consist of 8" & 7" &6" pipes according to A53/A 53M-2012, Grade B.			
3	50	Medium Voltage, 14m length, galvanized Steel poles consist of 8" & 7" &6" pipes according to A53/A 53M-2012, Grade B.			
4	130	Medium Voltage, 12m length, galvanized Steel poles, consist of 8" & 7" &6" pipes, according to A53/A 53M-2012, Grade B.			
5	510	Medium Voltage, 10m length, galvanized Steel poles, consist of 8" & 7" pipes, according to ASTM A53/A 53M-2012, Grade B.			
<b>Total Contract Price in Currency of</b>					

## Schedule (4)/ Price Summary/ option (2)

- This schedule price if the contractor cannot ship poles of 17m, 15 m and 14m as one piece.
- The tenderer shall enter in the appropriate columns of this schedule the prices at which each item will be supplied. Prices shall include shipment and delivery to the selected destination seen below based on the following selected transportation obligations.
- IDECO Company is not exempted from custom duties, sales taxes, import license fees and any other tariffs.
- Delivery period shall be expressed in weeks, it's recommended to start from the order awarding date. Transportation obligations shall be indicated as below:
  - ( ) CFR - Aqaba Port      ( ) CPT- Amman Customs      ( ) CPT- IDECO Stores

No.	Quantity Pcs	Material	currency	Unit Price	Total Price
1	1100	Medium Voltage, <b>12.5m</b> length, Galvanized Steel poles , consist of 8" & 7" pipes ( pole part (1) & pole part (2) of <b>15m</b> pole ) .			
2	50	Medium Voltage, <b>11.5m</b> length, galvanized Steel poles, consist of 8" & 7" pipes ( pole part (1) & pole part (2) of <b>14m</b> pole ) .			
3	130	Medium Voltage, <b>12m</b> length, galvanized Steel poles, consist of 8" & 7" & 6" pipes.			
4	510	Medium Voltage, <b>10m</b> length, galvanized Steel poles, consist of 8" & 7" pipes.			
5	1000	Medium Voltage, <b>7.5m</b> length, Galvanized Steel poles , consist of 7" & 6" pipes ( pole part (2) & pole part (3) of <b>17m</b> pole ) .			
6	1000	<b>8 Inches</b> , 10m length, 6.35mm wall thickness, 33.31 kG/m, outside diameter 219.1mm, Hot Dipped Galvanized Steel tubes.			
7	1160	<b>6 Inches</b> , 3.0m length, 5.56mm wall thickness, 22.31 kG/m, outside diameter 168.3mm, Hot Dipped Galvanized Steel tubes.			
<b>Total Contract Price in Currency of</b>					

## Inspection Details

- In case of foreign material origin, and inspection of material is required, the bidder shall fill the following table.

### Schedule No.5

NO.	Description	Cost
1	Inspection cost in the country of origin per engineer. (If not included in the main offer).	
2	Air flight class.	
3	Transportation cost during the period of inspection (Included/not included).	
4	Residential Hotel Rank.	
5	Daily meals (included/Not included), Number of meals.	
<b>inspection cost in third party in Jordan.</b>		
1	the cost of routine tests of the required materials as per <b>A53/A 53M-2012</b> or related standard conducted in Jordanian royal scientific (JRS).	
<b>Inspection cost in third party in country of origin</b>		
1	Third party lab. Name	

### Offer main details

- The bidder shall fill the following table otherwise his offer may be not considered.

### Schedule No.6

NO.	Description	
1	Value and currency of Bid Bond	
2	Payment method (open account/ LC/ Other)	
3	Offer validity	

**Tender Agreement Summary**  
**Tender No. (39 /2022)**

Dear Sir;

1. Having examined the conditions of Contract, specification and schedule for the above Works, the undersigned, offer to manufacture, supply, work, test, and deliver the said works described in the specification and schedules and in accordance with the said conditions of contract, for the sum of .....or such other sum as may be ascertained in accordance with the said conditions.
2. We agree that this tender shall be held open for acceptance or rejection for the validity period of **120 days** from the date fixed for opening tenders and it shall remain binding upon us and may be accepted at any time before the expiration of that period.
3. Unless and until a formal agreement is prepared and executed, this tender, together with your written acceptance thereof, shall constitute a binding contract between us.
4. If our tender is accepted, we will deliver to Irbid District Electricity Co. Ltd. Within **(30) days** of being called upon to do so a performance bond by bank or insurance company (to be approved in either case by the purchaser) to be jointly and severally bound with us in a sum equal to **10%** of the value of the contract. The form of the performance bond will be as attached hereto. We propose the following Bank or insurance company as surety (or sureties) in this respect:-  
.....
5. We undertake if our tender is accepted and on receipt of your acceptance to commence and manufacture, works test, and complete for delivery the whole of the Works offered within (.....) weeks calculated from the date of written acceptance of the tender, and to deliver on the dock at **Aqaba**, Jordan the whole of the works offered within a further (.....) weeks, or to **IDECO stores** within a further (.....) weeks.
6. We undertake to insure the materials against all risks from the time they leave the works until they are placed on board ship. We understand that marine insurance will be effected by Irbid District Electricity and we will provide details of the materials to be shipped in good time for Irbid District Electricity to arrange for the said marine insurance.
7. A guarantee Period will apply to each section of the works of fifteen months from the date of dispatch ex-works or twelve months from the date of setting to work whichever shall be the later.
8. We understand that you are not bound to accept the lowest or any tender you may receive.

Dated this .....day of / / 2022.

Signature.....in the capacity of .....

Duly authorized to sign Tender for and on behalf of.....  
Address..... Occupation.....